

# Manual

## Vacuum Degasser

### SDS 7510



## **Contents**

- 1. Standard Accessories**
  
- 2. Safety instructions**
  - 2.1. Safety instructions electrical hazards**
  - 2.2. General safety instructions**
  
- 3. Technical Specification**
  
- 4. Description of the Degasser SDS 7510**
  - 4.1. General description**
  - 4.2. Location of the degasser**
  - 4.3. Operation principle**
  - 4.4. Description front panel**
  - 4.5. Description Rear Panel**
  - 4.6. Pin Connection**
  
- 5. Maintenance**

## **1. Standard Accessory**

- Vacuum Degasser SDS 7510 (2, 3 or 4-channel; depending on the order)
- Power Cable
- for each installed degassing channel; 2 Teflon-capillaries for in and outlet (1.5 x 3 mm; 1 m) with fittings.
- Manual

## **2. Safety Instructions**

The manufacturer does not warrant for any defects or damage resulting from incorrect operation and maintenance, non-observance of the manual's instructions and negligence during installation.

**Before putting the instrument into operation, read carefully the manual and should there be any further questions, please get in contact with your supplier.**

### **2.1. General Electrical Hazards**

1. Check actual line voltage to confirm that the set voltage (on the rear side; voltage selector and fuse carrier) of the instrument is correct.
2. Before changing the instrument's voltage or before changing defective fuses, disconnect the instrument from all power sources.
3. The instrument has to be plugged into grounded wall sockets only
4. This instrument can be used only with other instruments which comply with the general safety regulations.

### **2.2. General Precautions**

1. In order to avoid any damages, perform periodic leak checks on all installed supply lines
2. The instrument is only allowed to be used for applications with specifications described under chapter 3.
3. For flammable and/or toxic solvent, follow a regulated approved waste disposal program. Never dispose of such products through the municipal sewage system.
4. The instrument is suitable for operation between 10 °C and 35 °C surrounding temperature.
5. For trouble-free and reliable operation, it is recommended to use only filtrated or particle-free samples for the degassing process.
6. The instrument should be cleaned with appropriate cleaning agents.

### **3. Specifications**

Degassing method:	With an applied vacuum, dissolved gases are continuously removed through a semi-permeable membrane	
Vacuum display:	0 - 999 mbar LCD display	
Flow rate:	max. 10 ml/min. for each degassing channel	
Efficiency:	0.5 ppm oxygen at 0.5 ml/min	
Parts which come in contact with the solvent:	PEEK and PTFE	
Volume per each channel:	8ml	
Analog output:	for documentation of the actual vacuum (0 - 1 V for 0 - 999 mbar)	
Error message:	visually over LED and through neutral relay contact	
Channels:	2 Channels without Display	Cat.- no.: SDS - 7510 - OD - 2
	3 Channels without Display	Cat.- no.: SDS - 7510 - OD - 3
	4 Channels without Display	Cat.- no.: SDS - 7510 - OD - 4
	2 Channels with Display	Cat.- no.: SDS - 7510 - D - 2
	3 Channels with Display	Cat.- no.: SDS - 7510 - D - 3
	4 Channels with Display	Cat.- no.: SDS - 7510 - D - 4
Power supply:	230/110 V    50/60 Hz	
Dimensions:	110 x 150 x 350 mm	
Weight:	5.6 kg	

## **4. Instrument Description**

### **4.1. General Description**

The degassing of solvents is very important in liquid chromatography, as oxygen and other in the solvent dissolved gases affect the analysis for various reasons:

through volume contraction (gradient mixing), different pressure ratio (in front and behind the column) and caused by different temperatures, the dissolved gases are set free in course of time. This will influence the reliability of the analysis (pump side) as well as the detection efficiency (measuring cell). Therefore, dissolved gases have to be removed from the solvent.

The best known methods are ultrasonic's and vacuum processing, flushing of the solvent with a stream of helium and vacuum degassing devices.

The ultrasonic method is suitable for degassing organic eluents but is not adequate enough for hydrous solutions. For these kind of solutions, the solvent has to be degassed in a suction bottle placed under vacuum. But both of these methods are only short-term solutions as after the degassing process, the solvent will be continuously enriched with gases taken from the air. Furthermore, for gradient elution, the degassing quality is not sufficient enough.

The known methods are ultrasonic's and batch vacuum processing, flushing of the solvent with a stream of helium and continuous vacuum degassing devices.

Continuously usable and quite simple to handle is the method of flushing the solvent with a stream of helium. Hereby, the stable remaining He-molecules are displacing all other gases. An equal maintained gas pressure buffer prevents the helium from escaping and gradient elution's can be carried out without any problems.

The same solvent quality is achieved with the usage of a vacuum device. The great advantage when using the vacuum device is, that no further costs concerning the supply and consumption of helium arise. Furthermore, for some analysis methods, e.g. detection in the lower UV rang or with RI-detection, the vacuum degassing method allows an Operation with lowest possible detection limits due to more smooth and stable base line runs.

## **4.2. Location of the Degasser**

The degasser is only allowed to be installed on the suction side of a HPLC pump or with gradient elution, positioned in front of the mixer.

With the help of the delivered Teflon capillaries, each single solvent has to be connected to the fittings positioned at the right and left side of the coded channel. Through one of the capillaries, the solvent is transported from the reservoir into the degasser and the degassed solvent is leaving the degasser through the other capillary which is connected to the analyzing system. The degassing efficiency is independent of the flow direction, however, it is recommended to have uniform connections for all of the solvent inlets and outlets.

Before putting the degasser in operation, all connected capillaries have to be filled with the eluent. This is done after the installation with the help of the delivered syringe. The syringe is connected at the pump% relief valve and the solvent is sucked on as long as there is none air bubbles remaining in the capillaries.

Already after a warm-up time of approx. 3 to 5 minutes, the degasser is ready for operation.

### 4.3. Operation Principle of the Degasser

In a vacuum chamber, the solvent to be degassed is distributed into several, parallel arranged, semi-permeable membrane chambers. The integrated membrane coils (each consists of about 10 Teflon capillaries with a length of approx. 10 m) is located in a vacuum chamber. When a high vacuum (more than -850 mbar) is applied, only the in the liquid dissolved gases are diffusing through the thin membrane into the vacuum chamber.

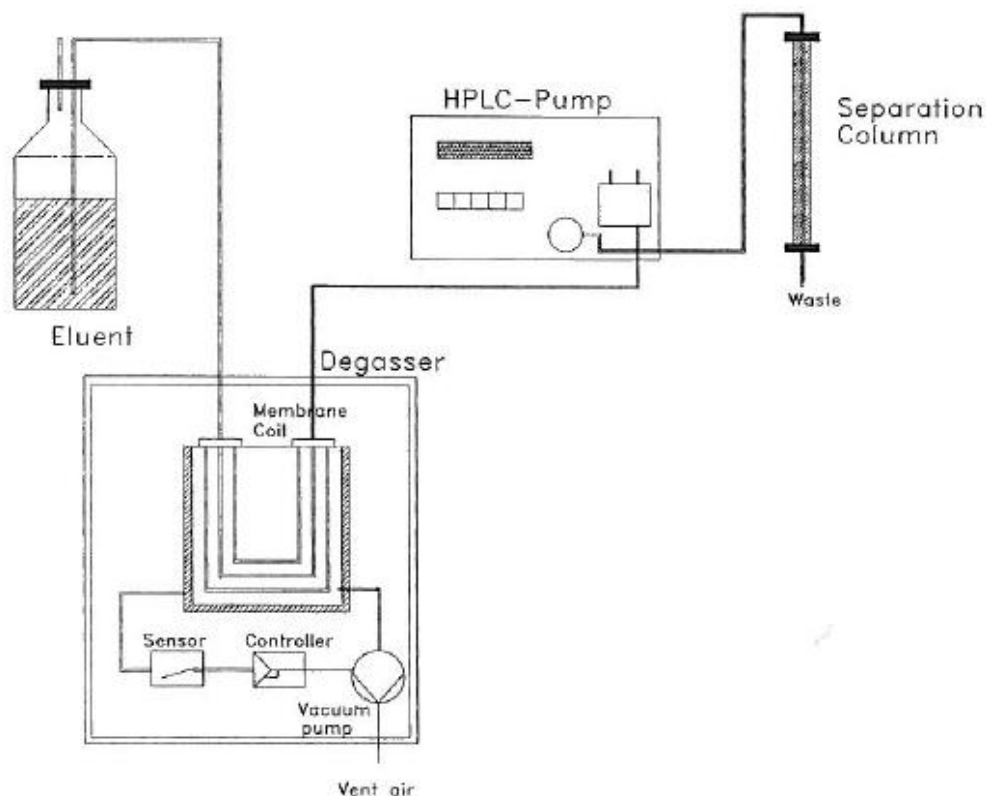
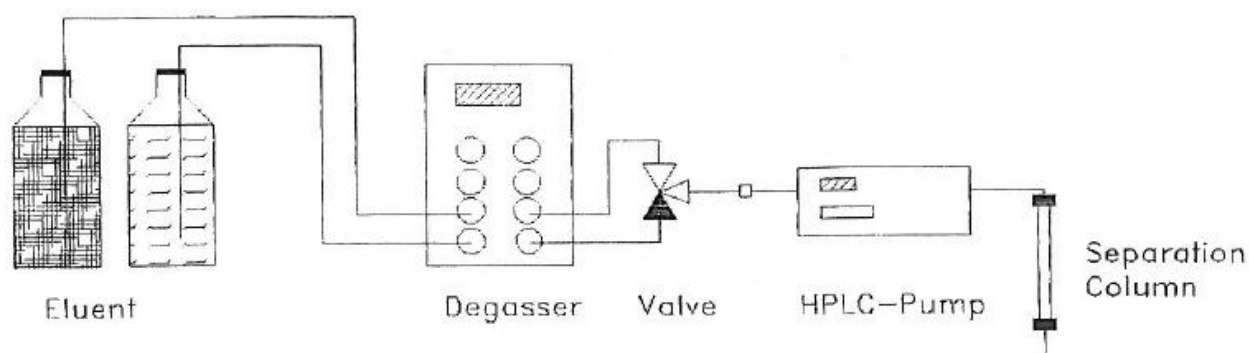

**Fig. 1** The vacuum pump is controlled with a pressure switch, so a vacuum is constantly applied (between approx. -850 up to approx. -890 mbar).

With a total solvent volume of 8 ml per degassing channel, the Degasser SDS 7510 achieves an extremely low remaining gas concentration of 0.5 to 5 ppm oxygen, depending on the Degasser's flow rate (0 to 10 ml/min.).

### Operation in combination with low-pressure gradient application

The below described (Fig. 2) figure shows an example of a flow diagram which can be applied for the degassing process with low-pressure operation



**Fig. 2: Flow diagram of a low-pressure system with installed degasser**

Example: Both eluents are connected to separate degasser channels.

### Operation with high-pressure application

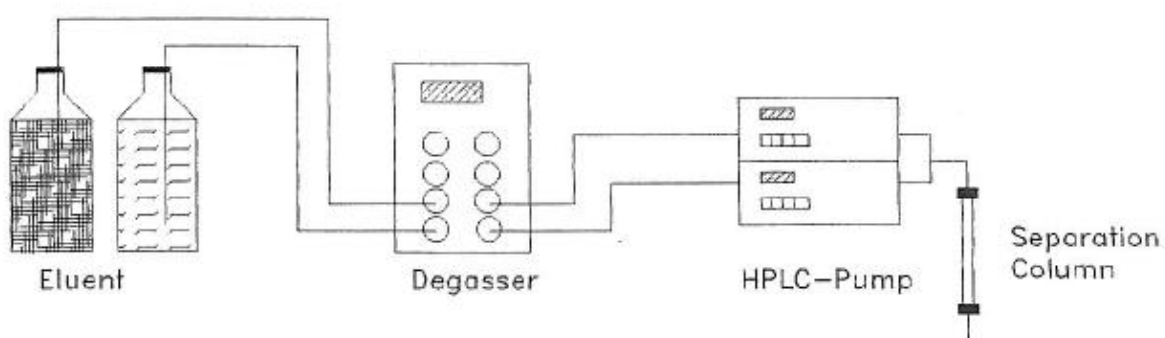
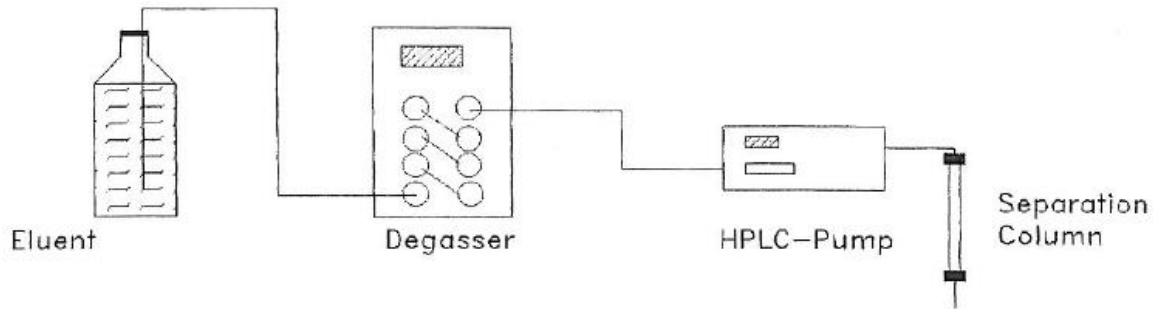

**Fig. 3: Flow diagram of a high-pressure system**

Example: Both eluents are also connected to two separate degasser channels.

### Increase in degassing quality

The degassing quality can be improved by coupling two **or** several membrane channels. For this, the channels have to be connected according to fig. 4.



#### **4.4. Description of the Front Panel**

The vacuum degasser SDS 7510 is available for degassing 2, 3 or 4 solvents, depending on the ordered degasser model.

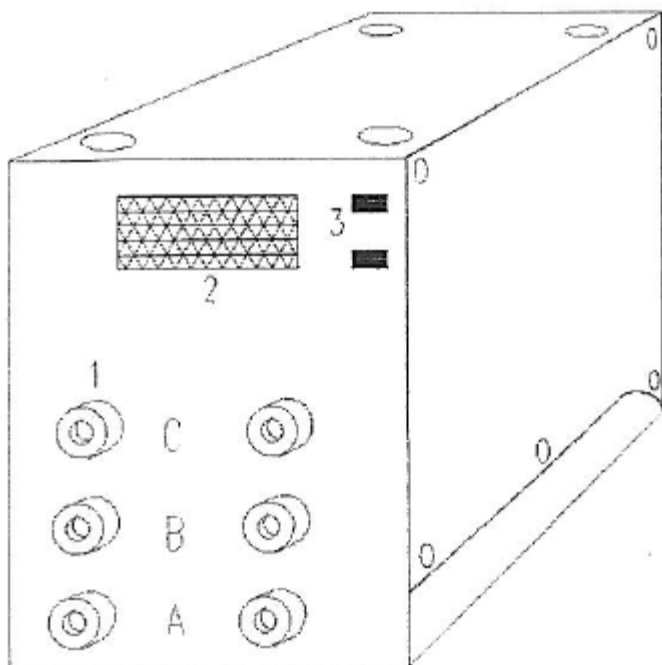

**Fig. 5: Front Panel**

1. In and outlet of the solvents
2. LCD display of the vacuum
3. LED display

**PUMP (green):** The vacuum is below the set value. The integrated vacuum pump is in operation until the set value is reached again.

**ERROR (yellow):** The set vacuum value is not achieved after some time (i.e. the pump is still working). If this error is displayed for a longer period of time, the pump will switch off automatically.

#### **4.5. Back Panel**

At the rear panel, the mains connection, the analog pressure output/the error message contacts are installed. Also, the fitting for directing possibly existing solvent traces to the laboratory's ventilation can be found at the rear panel.

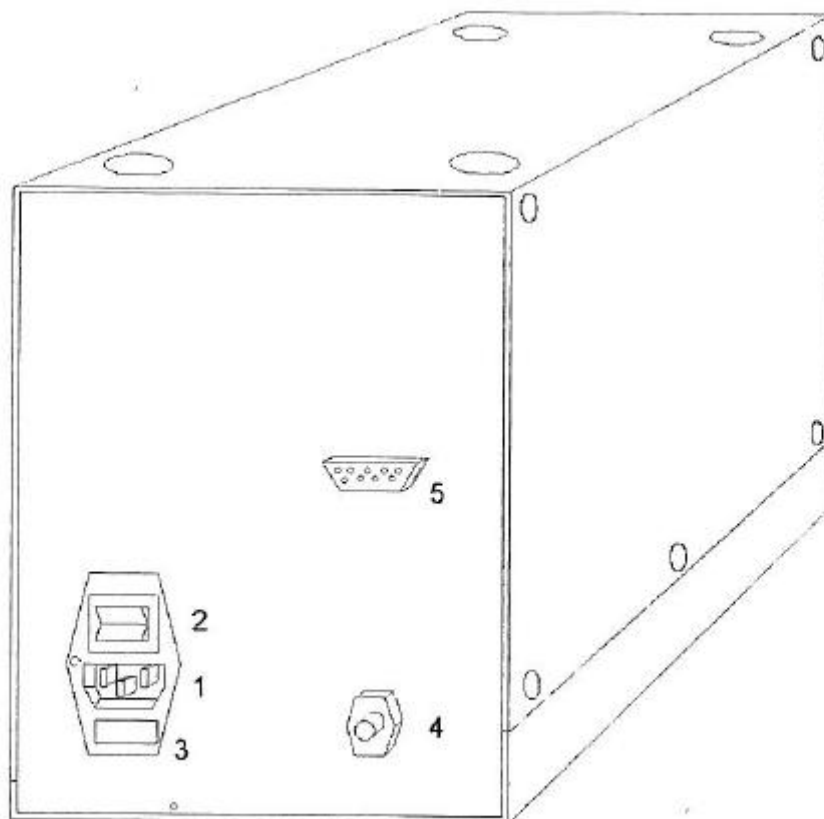

**Fig 6: Rear panel of the degasser**

1. Power Supply (230 Vac)
2. Master Switch
3. Voltage selector and fuse carrier (2 fuses 200 mA T)
4. Tube connection: for removing toxic solvents (e.g. THF), a tubing (e.g. Silica tube with i.d. of 5 mm) should be installed to direct the solvent into the ventilation
5. Interface which allows the documentation of the actual pressure output and also the error messages.

#### **4.6. Pin Connection of the Interface**

Analog pressure	1	0			
(0-1 V; pos. Volt.)			0	6	analog pressure
not connected	2	0			(0-1 V; neg. Volt.)
			0	7	not connected
Error relay NO	3	0			
			0	8	Error relay COM
Error relay NC	4	0			
			0	9	Error relay COM
not connected	5	0			

#### **5. Maintenance**

When using the degasser for solvents with a high salt concentration, the system should be flushed with dest. water occasionally.