

POPULAR CONFIGURATION GCs

Transformer Oil Gas Analyzer (TOGA) GC

System Overview

The TOGA GC system is designed to analyze transformer oil directly from the sampling syringe to minimize contamination exposure. Determine the type and quantity of gases dissolved in transformer oil. Equipped with a TCD detector, HID detector, or both. Dual 10-port gas sampling valves with solenoids for helium purge/flush.

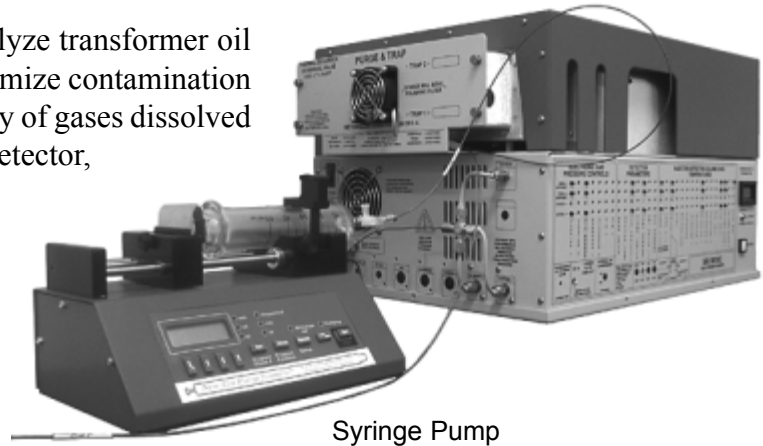

Syringe Pump

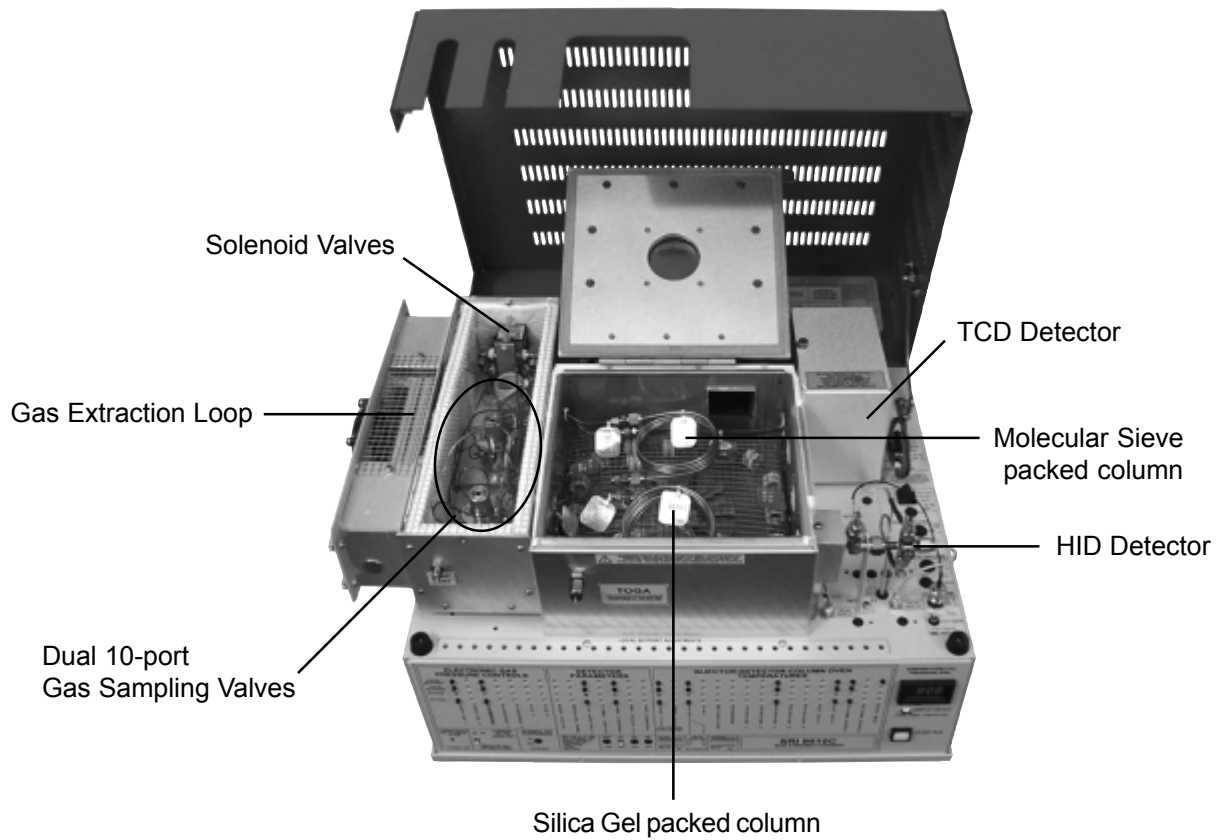

The TOGA GC may also be used to perform more general DGA (dissolved gas analyses) with sample liquids like water and soft drinks.

POPULAR CONFIGURATION GCs

Transformer Oil Gas Analyzer (TOGA) GC

Theory of Operation

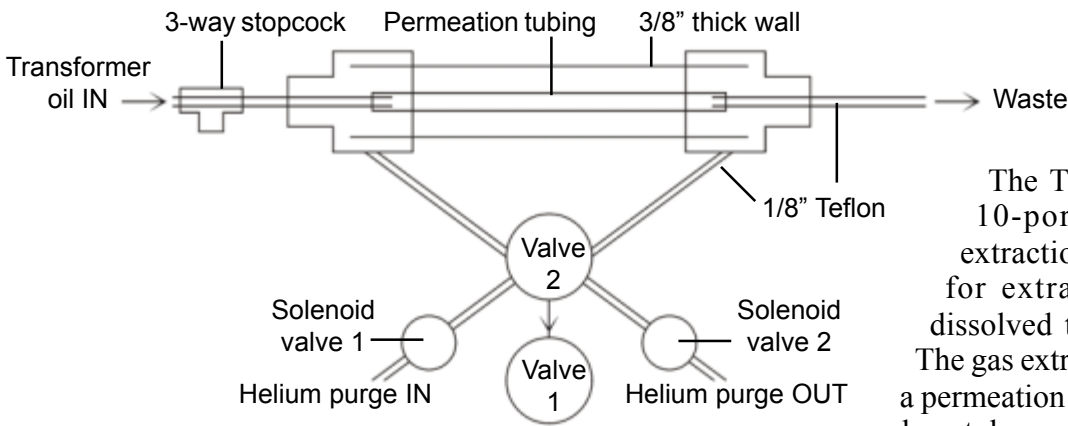

The TOGA GC uses a dual 10-port valve and gas extraction loop configuration for extracting and injecting dissolved transformer oil gases. The gas extraction loop consists of a permeation tube encapsulated in a glass tube equipped with a heated trap, and replaces the sample loop in the valve circuit. Teflon tubing is used to convey the sample oil from the syringe to the permeation tube, and from the permeation tube out to waste. The Teflon tubing and the permeation tube are secured in the gas extraction loop, with the permeation tube centered in the glass tube which functions as the extraction chamber. When the transformer oil is pumped through the permeation tube, the dissolved gases therein selectively permeate through the heated (70°C) membrane into the surrounding extraction chamber. Plumbed to the dual 10-port valves are two solenoid valves for purging the gas extraction chamber with helium between sample injections, to prevent carryover.

LOAD:

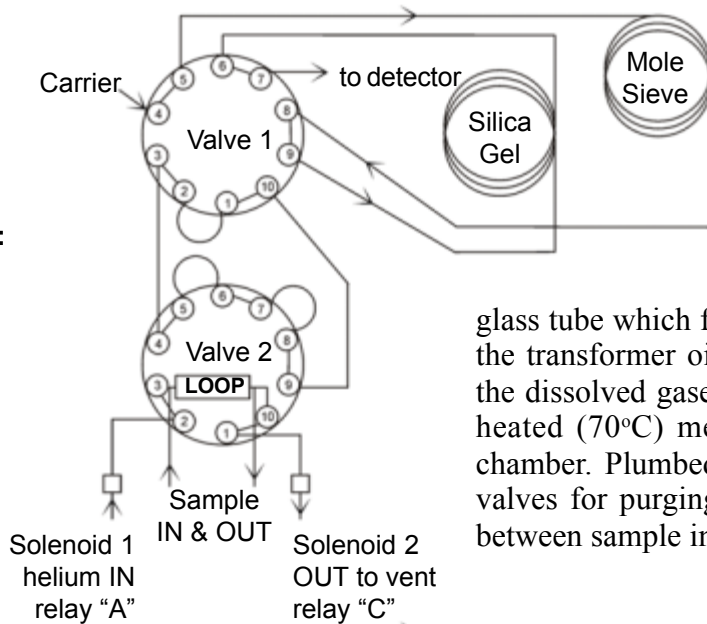

Valve 1 is plumbed to the Molecular Sieve 13X column, then to the Silica Gel column. Valve 2 is plumbed to the gas extraction loop. While the transformer oil is being pumped through the gas extraction loop, both valves are in the LOAD position. During this time, the gases dissolved in the transformer oil are extracted by selective permeation through the membrane.

INJECT:

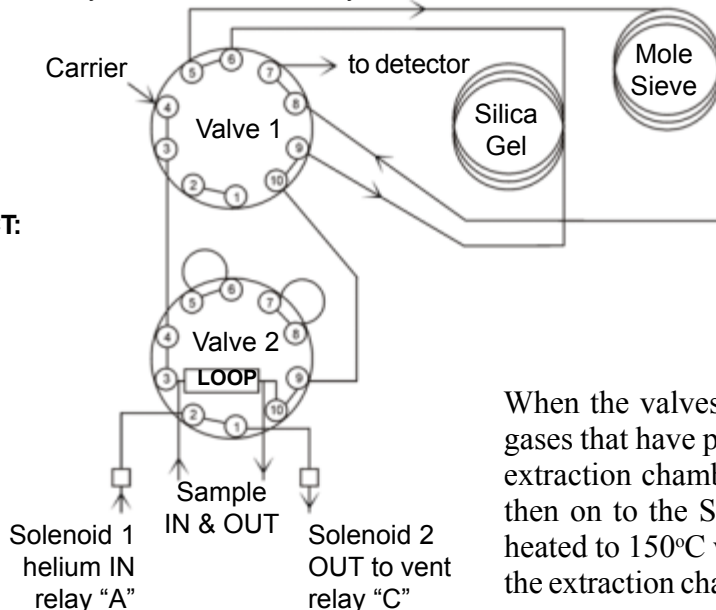

When the valves are rotated into the INJECT position, the gases that have permeated the membrane are swept from the extraction chamber onto the Molecular Sieve 13X column, then on to the Silica Gel column. The permeation tube is heated to 150°C while the solenoids are turned ON to sweep the extraction chamber clean with helium for the next sample.

POPULAR CONFIGURATION GCs Transformer Oil Gas Analyzer (TOGA) GC

Expected Performance

These two chromatograms show a 100ppm DGA standard as separated by the TOGA GC. The permeation chamber was baked out at 150°C between runs.

Sample: 10mL 100ppm DGA standard
 Columns: 1-meter Molecular Sieve, 2-meter Silica Gel
 Carrier: Helium @ 20mL/minute
 Pump rate = 0.5mL/minute
 Valve oven temp = 90°C
 Permeation tube temp = 70°C

Temperature program:
 Initial Hold Ramp Final
 40.00 7.000 10.000 100.00
 100.00 0.000 20.000 250.00
 250.00 5.000 0.000 250.00

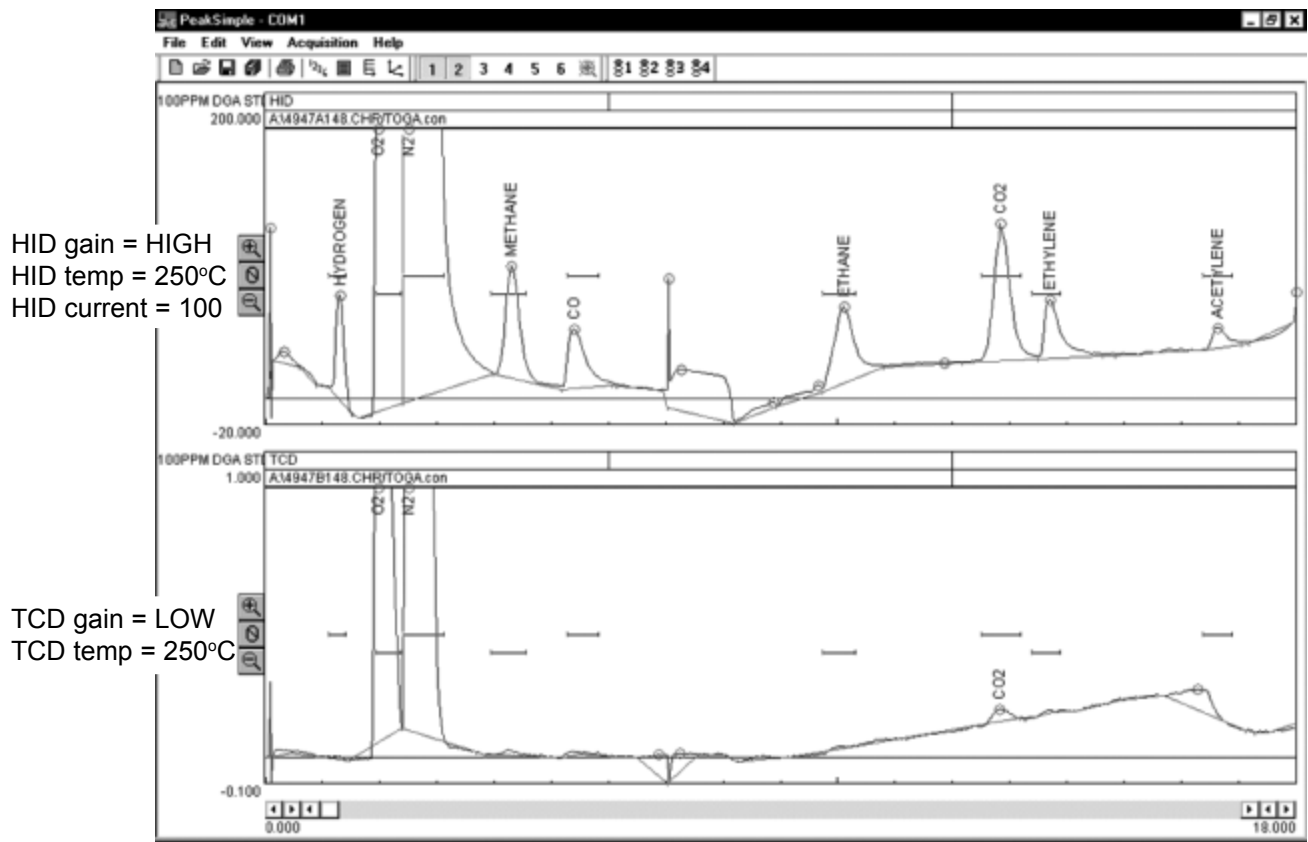

Events:

Time	Event
0.000	ZERO
0.050	G ON (VALVE 1)
0.050	H ON (VALVE 2)
0.300	H OFF
0.500	C ON (OUTLET SOLENOID)
0.550	A ON (INLET SOLENOID)
0.600	F ON (TRAP HEAT)
7.000	G OFF
9.000	F OFF
10.000	A OFF
10.200	C OFF

Results:

Component	Retention	Area
Hydrogen	1.283	732.8160
O2	1.950	76505.4300
N2	2.483	118654.2520
Methane	4.283	1388.4300
CO	5.366	1083.2865
Ethane	10.083	1247.8820
CO2	12.816	1941.6180
Ethylene	13.683	798.1490
Acetylene	16.616	251.2315

POPULAR CONFIGURATION GCs

Transformer Oil Gas Analyzer (TOGA) GC

General Operating Procedure

1. Set up the syringe pump to the left of the GC, so it is in close proximity to the TOGA gas extraction and injection system.
2. Connect your helium source to the carrier and detector make-up gas inlets on the lower left-hand side of the GC. The pressures correlating with the proper flow rate for your instrument are printed on the right hand side of the GC, in a table under the heading GAS FLOW RATES. For best EPC performance, set the incoming helium pressure 15-20psi higher than the pressure listed in the table.
3. Turn the GC ON and let the system warm up and stabilize. Once you have ensured proper carrier gas flow, turn the TCD gain switch to LOW (this turns the current ON). The TCD temperature is factory set at 250°C. You may adjust this temperature if required. Turn ON the HID current. The HID temperature is also factory set at 250°C. Set the HID gain switch to HIGH. See each separate detector's manual section for more operating details.
4. Type in the following column oven temperature program for channel 1:

Temperature program:

Initial	Hold	Ramp	Final
40.00	7.000	10.000	100.00
100.00	0.000	20.000	250.00
250.00	5.000	0.000	250.00

5. Type in the following event table for channel 1:

Events:

Time	Event
0.000	ZERO
0.050	G ON (VALVE 1)
0.050	H ON (VALVE 2)
0.300	H OFF (VALVE 2)
0.500	C ON (OUTLET SOLENOID)
0.550	A ON (INLET SOLENOID)
0.600	F ON (TRAP HEAT)
7.000	G OFF (VALVE 1)
9.000	F OFF (TRAP HEAT)
10.000	A OFF (INLET SOLENOID)
10.200	C OFF (OUTLET SOLENOID)

6. Insert a glass syringe full of transformer oil into the syringe pump cradle. Connect the syringe outlet to the gas extraction loop inlet through the three-way stopcock.
7. Turn ON the two solenoids for 30 seconds to pre-purge the extraction chamber. Open solenoid C first, then A. Close A first after 30 seconds, then close C. Maintain this order to avoid collapsing the permeation tubing under excess gas pressure.
8. Turn ON the syringe pump at the rate of 0.5mL/minute. Let it pump until the waste line is full. Turn the syringe pump OFF.
9. Purge the extraction loop for 30 seconds.
10. Once the Teflon lines have been filled with oil and the extraction chamber purged, start the pump again to extract the dissolved gases from the sample. 10mL (or more) should be enough sample oil to yield reasonable detection limits.
9. Hit RUN on the front of the GC or hit the spacebar on your computer keyboard.

POPULAR CONFIGURATION GCs Transformer Oil Gas Analyzer (TOGA) GC

Changing the Permeation Tube

1. Remove the plate covering the gas extraction loop by unscrewing the four brass thumbscrews that hold it in place, and unplugging the fan power cord. Remove the two squares of white insulation to reveal the permeation tube assembly. Gently slide the assembly out of the valve oven ducts.

2. Loosen the glass tube's two stainless steel nuts and Teflon ferrules with a wrench to free the Teflon line. The fittings with the attached gas line are stationary.

3. Slide the Teflon tubing out of the glass tube until you can see the permeation tube.

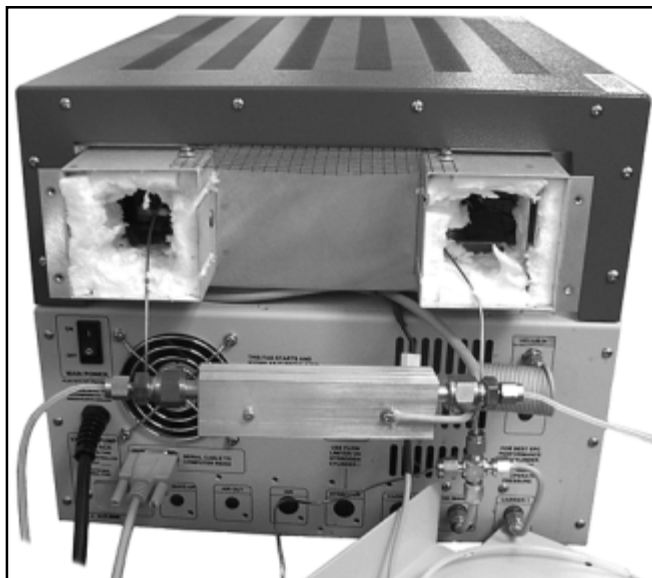

4. Pull the old permeation tube off the Teflon tubing and discard. Wipe any oil off the Teflon tubing with a KimWipe or other lint-free wipe.

5. Slide the permeation tube over one end of the Teflon tubing. It is a tight squeeze to get the Teflon tubing into the permeation tube. To facilitate this, the Teflon tubing is cut at a 45° angle or sharper. Slide it on about 3/4" on each side. The permeation tube should be 7 inches long. It will be stretched slightly inside the glass tube.

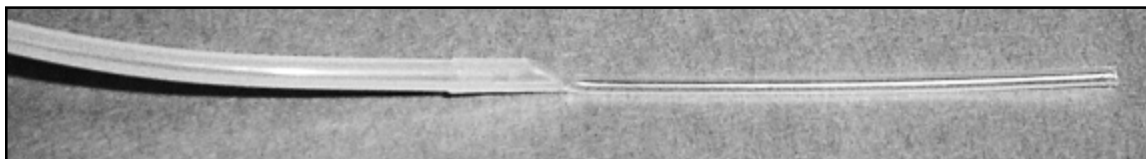

6. Slide the permeation tube and Teflon tubing back into the glass tube and center it.

7. Re-secure the two stainless steel nuts and Teflon ferrules onto the Teflon tubing. Make sure that the permeation tubing protrudes beyond the stainless steel nut, so that the nut and the ferrule are securing it to the Teflon tubing. You may have to stretch the permeation tubing a bit to fasten it with the nuts and ferrules. While you are tightening the nuts and ferrules, firmly grip the Teflon tubing where it protrudes about 2-3" from the end of the trap to avoid twisting or kinking the permeation tube. When you are finished, check the flow through the permeation tube to ensure there is no constriction (it should be the same as it was before you replaced the permeation tube). Once the transformer oil starts flowing through the permeation tube, it will stretch, resulting in a corkscrew appearance, which is normal for operating mode.

8. Slide the entire assembly back into the valve oven ducts. Replace the two squares of white insulation. Replace the cover plate and secure its four thumbscrews.