



Rheodyne Part Numbers

Models 7010 and 9010

Sample Injection Valves

7010

9010

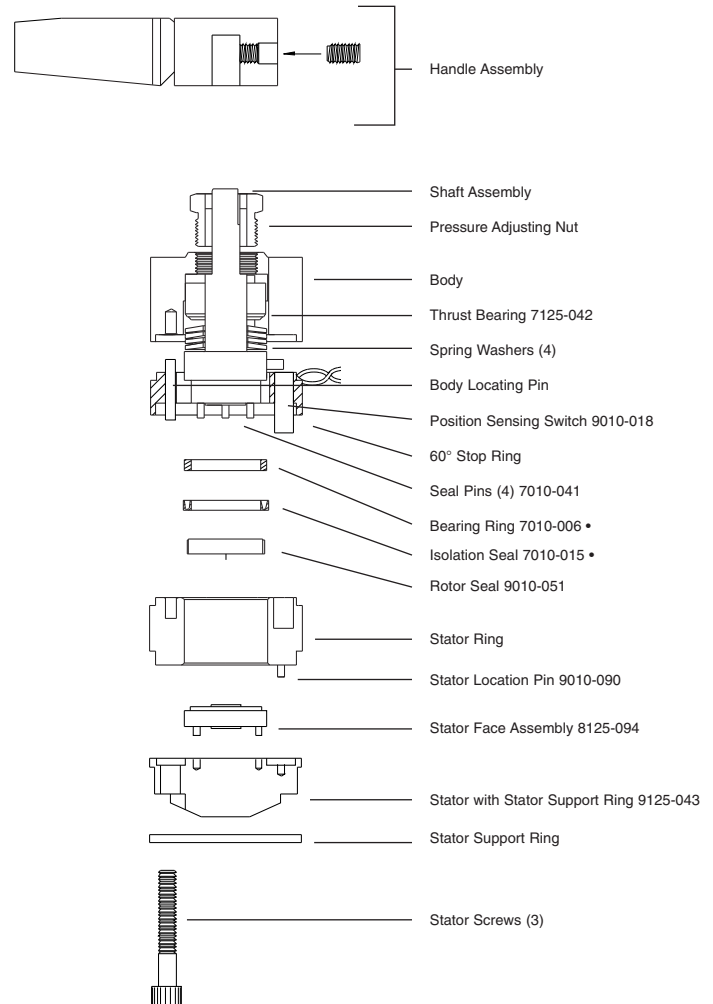
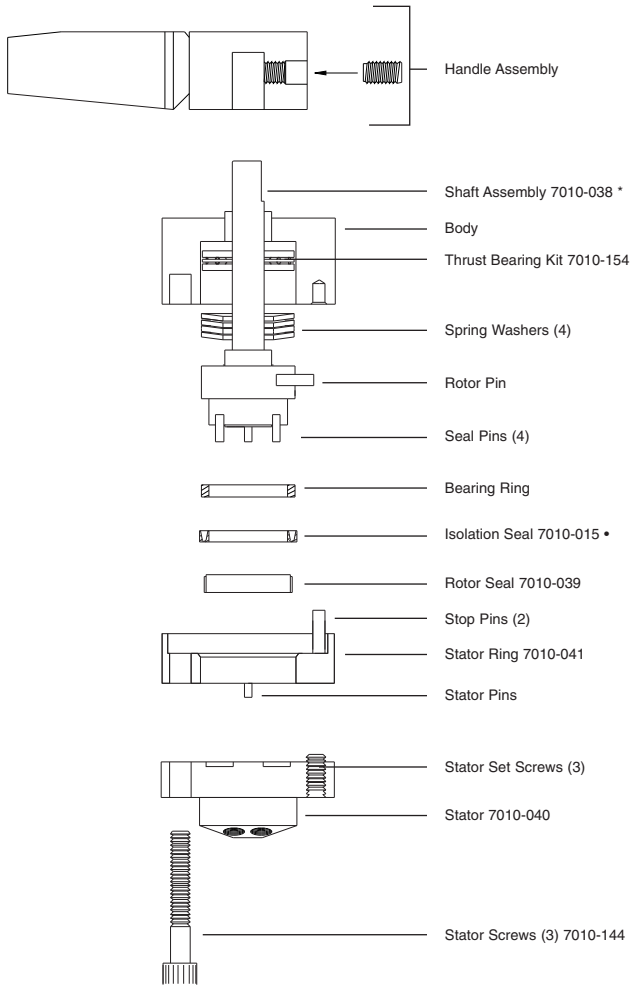

RheBuild® Kit (P/N 7010-999)

RheBuild Kit (P/N 9010-999)

• Parts common to all 3 valves
 ° Handle assembly includes knob, handle, set screws
 * Shaft Assembly includes shaft, rotor pin, seal pins